

HDF LBP

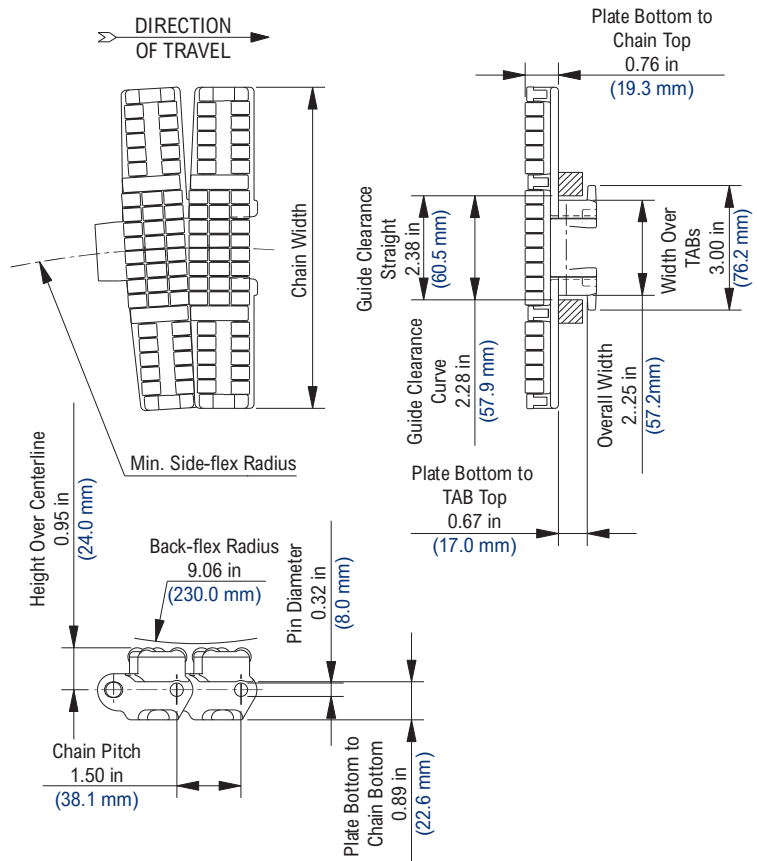

Chain Information

desc	Chain Width		Min. Side-flex Radius		Approximate Weight	
	in	mm	in	mm	lbs/ft	kg/m
3 3/4	3.75	95.3	26.25	666.8	2.25	3.35
7 1/2	7.50	190.5	24.00	609.6	3.03	4.51
10	10.00	254.0	24.00	609.6	3.84	5.72
12	12.00	304.8	26.77	680.0	4.29	6.39



Available Materials

Prefix	Chain Material	Standard Pin Material	Temperature						Chain Strength		FDA Approval
			Fahrenheit			Celsius			lbs	N	
			min	max	wet	min	max	wet			
Standard Materials											
XLA	Internally Lubricated Polyacetal	Stainless Steel	-40	180	150	-40	82	66	625	2,780	Yes

Regulatory Information

The Food and Drug Administration (FDA) accepts certain materials for direct food contact. FDA approved material is compliant to FDA 21 CFR § 177. Rexnord, MCC, and TableTop are trademarks of Rexnord Corporation. All rights reserved.

Additional Notes

Stocked in 40 pitch, 5 ft (1.524 m) length strands. Typical coefficient of friction between chain and product = 0.07. Chain strength is listed at room temperature. NR = Not Recommended. For additional material information, see material portfolio.